

MedCo Technology Gantry

A Portable and Versatile Overhead Ceiling Lift System



The MedCo Technology Gantry provides the benefits of a ceiling track system without incurring the cost and inconvenience of a permanent installation. Our Gantry also allows users the flexibility to move a ceiling lift from room to room. It is the perfect solution for care areas with budget constraints that can benefit from portable lift coverage. The MedCo Technology Gantry combines the advantages of a ceiling lift with new and unique portability features, making it the safest and most user-friendly system available.

- Up to 1,000 Lb / 454 Kg Safe Working Load (SWL)
- Adjustable Height and Width
- Tool-Free Adjustment Allows Quick and Safe Transport
- Easier to Set Up Compared to Other Gantry Systems
- Fits Through Doorways and Inside Most Elevators
- Free-Flowing, Lockable Casters for Easy Repositioning

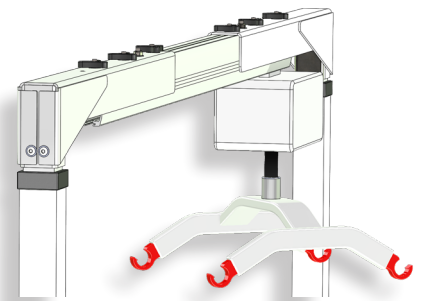

The Molift AIR is a strong and smooth hoist that enables patients to be transferred in a comfortable and safe manner. Suitable for seated or supine transfers and ambulation. It is a very light motor which, in combination with the quick release coupling system, provides easy handling when mounting and servicing. We offer three models with various lifting capacities.



Molift Service Tool

The Molift Service Tool is a unique software package which can be connected to all Molift motorized products enabling a qualified service personnel the ability to read, verify and analyze the key parameters in the lift. This makes it an effective tool for reading the service history and ensuring that the lift is working properly.

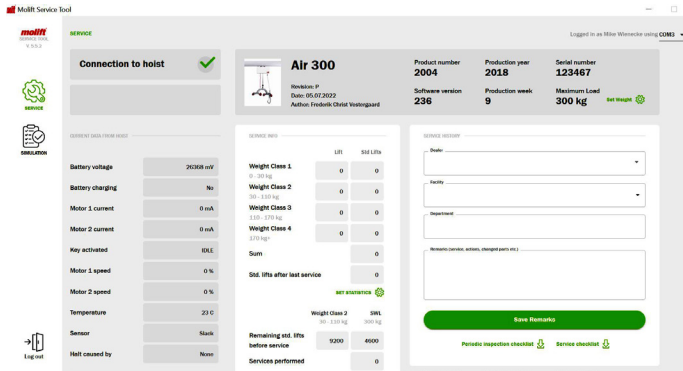

- Allows clinicians to assess product utilization by frequency and patient weight class
- Weight class settings can be customized to meet the needs of the facility
- Allows for recording of product placement date, placement location, and service intervals
- Allows Biomedical Engineering to assess general equipment condition during normal preventive maintenance and diagnose problems as needed

The MedCo Technology Gantry is Perfectly Suited for MedCo Slings



Single Patient Seated
SHB-1PS-(S,M,L,XL)



Advantage Seated
SHB-ADV-(S,M,L,XL)



Ambulation Shorts
AS-APEX
XS,S,M,L,XL,2XL,3XL
BARI80, BARI120



APEX Repositioning
REP-APEX-STD

MedCo Technology Gantry Specifications

Part Number	MTG660L	MTG770L	MTG1000L
Molift AIR Safe Working Load (SWL)	660 lb / 300 kg	770 lb / 350 kg	1,000 lbs / 454 kg
Length Closed	80.5 in / 204.5 cm		
Length Open	106 in / 269.2 cm		
Minimum Height	79 in / 200.7 cm		
Maximum Height	97 in / 246.4 cm		
Total Width	40 in / 101.6 cm		

